

INVITATIONAL 2018-2019

A+ ACADEMICS

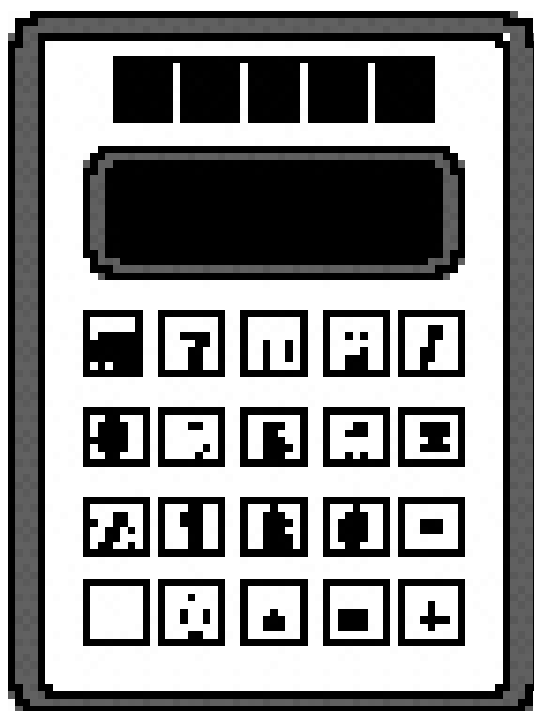

University Interscholastic League



Calculator Applications

**DO NOT OPEN TEST
UNTIL TOLD TO DO SO**

How to Write the Answers

A. For all problems except stated problems as noted below—write three significant digits.

1. Examples (* means correct but not recommended)

Correct: 12.3, 123, 123.*, 1.23x10*, 1.23x10^{0*}
1.23x10¹, 1.23x10⁰¹, .0190, 0.0190, 1.90x10⁻²

Incorrect: 12.30, 123.0, 1.23(10)², 1.23·10², 1.230x10²,
1.23*10², 0.19, 1.9x10⁻², 19.0x10⁻³, 1.90E-02,

answers written in parentheses(), brackets[] or braces{} are incorrect

2. Plus or minus one digit error in the third significant digit is permitted.

B. For stated problems

1. Except for integer and dollar sign problems, answers to stated problems should be written with three significant digits.

2. Integer problems are indicated by (integer) in the answer blank. Integer problems answers must be exact, no plus or minus one digit, no decimal point or scientific notation.

3. Dollar sign (\$) problems should be answered to the exact cent, but plus or minus one cent error is permitted. Answers must be in fixed notation. The decimal point and cents are required for exact-dollar answers.

2019 University Interscholastic League MS/JH Calculator Contest A

19X-1. $955 - 1070$ ----- 1= _____

19X-2. $22 - 16 - 57$ ----- 2= _____

19X-3. $-27.8 + 6.19 + 26.2$ ----- 3= _____

19X-4. $\pi - 6 - 13 + 15$ ----- 4= _____

19X-5. $-386 - 1110 - 922 - 1030$ ----- 5= _____

19X-6. $39.9 - 39.3 - 49.7 + 141 + 88.4$ ----- 6= _____

19X-7. $1.72 + 1.35 + 1.5 + 1.16 + 0.884$ ----- 7= _____

19X-8. $(0.941 + 3.89 - 3.68) - (1.88 + 3.65)$ ----- 8= _____

19X-9. $81.6 \times 33.9 \times 557$ ----- 9= _____

19X-10. $147 \times 507 \times 137 \times 1300$ ----- 10= _____

19X-11. What is the positive value for the difference in 31.7 and 16.3 times pi? ----- 11= _____

19X-12. If one-inch equals 2.54 centimeters, then how many inches are in 375 centimeters? ----- 12= _____ in

19X-13. If there are on average 3538 ants in an ant mound, how many ant mounds (Am) are there for one million ants? ----- 13= _____ Am

- 19X-14. $(61)[68 \times 147 \times 59]$ -----14= _____
- 19X-15. $(102/75)[78 - 58]$ -----15= _____
- 19X-16. $\left[\frac{130}{504}\right][(366/769) - 0.148]$ -----16= _____
- 19X-17. $\left[\frac{115}{49}\right] [(134/56) + 2.35]$ -----17= _____
- 19X-18. $\frac{(146/135) + (39/39)}{(0.0428 - 0.121)}$ -----18= _____
- 19X-19. $\left[\frac{(3110/3460) - (2670/2040)}{1.87/(2.69)}\right]$ -----19= _____
- 19X-20. $\frac{618}{(509 - 329)} - \frac{(765 - 688)}{172}$ -----20= _____
- 19X-21. $(0.49)[51/119 \times 101/66] - 0.298$ -----21= _____
- 19X-22. $\frac{(\pi)(418/551)(641/75)}{(669/527)}$ -----22= _____
- 19X-23. $\frac{(0.00312 + 0.00241 - 0.00141)}{\{(0.0127 - 0.0047)/(877)\}}$ -----23= _____
- 19X-24. A tree has a root whose longest length is 89.3% of its height above ground. If the tree is 24 feet 6 inches tall, how long is the tree's longest root? -----24= _____ feet
- 19X-25. Li has quiz grades of 87, 79, 91, 90 and 98. What is the lowest grade that Li can make on the next quiz and have an average of eighty-five?-----25= _____ Integer
- 19X-26. Anna was barbecuing for some friends, so she bought 10 Lbs. of hamburger meat at \$4.99 per Lb., six packages of buns at \$1.99 per package, four tomatoes at 49¢ each, a package of sliced cheese at \$2.39, a head of lettuce at 59¢ and six 2-liter bottles of soda at \$1.59 per bottle. How much did it cost her for all this food and drink? -----26=\$ _____

19X-27. $\frac{(6.46 \times 10^5) + (3.00 \times 10^5)}{(-0.163)(0.494) - 0.052}$ -----27= _____

19X-28. $\frac{(0.0801 + 0.0521)(17.9 + 32.8)}{(1.85 \times 10^{12})}$ -----28= _____

19X-29. $(46.5) \left[(7.82 \times 10^{-4} / 0.00142)(23.3 + 4.88) \right]$ -----29= _____

19X-30. $(18.3) \left[(4.64 \times 10^{11}) - (2.11 \times 10^{11}) \right]$ -----30= _____

19X-31. $\frac{(0.0157 + 0.00923)}{(1.92 \times 10^{11})}$ -----31= _____

19X-32. $\frac{1}{0.583} + \frac{1}{(1.39 - \pi)}$ -----32= _____

19X-33. $\frac{1}{59.5} - \frac{1}{92.7} + \frac{1}{158}$ -----33= _____

19X-34. $\left[\frac{1}{865} \right] + [0.982]$ -----34= _____

19X-35. If today one \$US equals 112.30 Japanese Yen (¥) and one Euro (€) equals 1.1677 \$US, how many Yen equal 250 Euros? -----35= _____ ¥

19X-36. A 50 Lb. bag of fertilizer stated that it was 15% Nitrogen, 10% Phosphorus and 12% Potassium. How many pounds of the fertilizer were just filler? (i.e. not any of the ingredients mentioned)-----36= _____ Lbs.

19X-37. RECTANGLE

Area = 49300

396

?

19X-37 = _____

19X-38. CIRCLE

Diameter = 0.38

Area = ?

19X-38 = _____

19X-39. $(2.79 + 1.29 + 2.46)^2(0.133 + 0.115)^2$ -----39= _____

19X-40. $\left[\frac{1.62}{2.08}\right](2.78 + 5.43)^4$ -----40= _____

19X-41. $\left[\frac{11300 + (1/(5.18 \times 10^{-5}))}{(10700/19400) - 0.302}\right]^2$ -----41= _____

19X-42. $(1/(8.49 \times 10^{-4}))(9650 - 1710)^3$ -----42= _____

19X-43. $\sqrt{1270} + \sqrt{1020 + 1160} - (\pi)\sqrt{685}$ -----43= _____

19X-44. $(1250)\sqrt{1360 + 684 + 497}$ -----44= _____

19X-45. $\sqrt{5.86 - 6930/2560} + 1/\sqrt{0.0113 + 0.0498}$ -----45= _____

19X-46. $\frac{1}{\sqrt{1300 + 1040 + 1310}} + \left(\frac{1}{\sqrt{7.41}}\right)^4$ -----46= _____

19X-47. Matt and Mike stood back to back at the starting line of a circular track with a diameter of 50 yards. When the race started Mike ran with a speed of 12 feet/sec while Matt ran in the opposite direction with a speed of 11.5 feet/sec. How long did it take the two boys to meet? -----47= _____ min

19X-48. If one ream of printer paper has 500 sheets and is 2 in. thick, how thick is each sheet? -----48= _____ mm

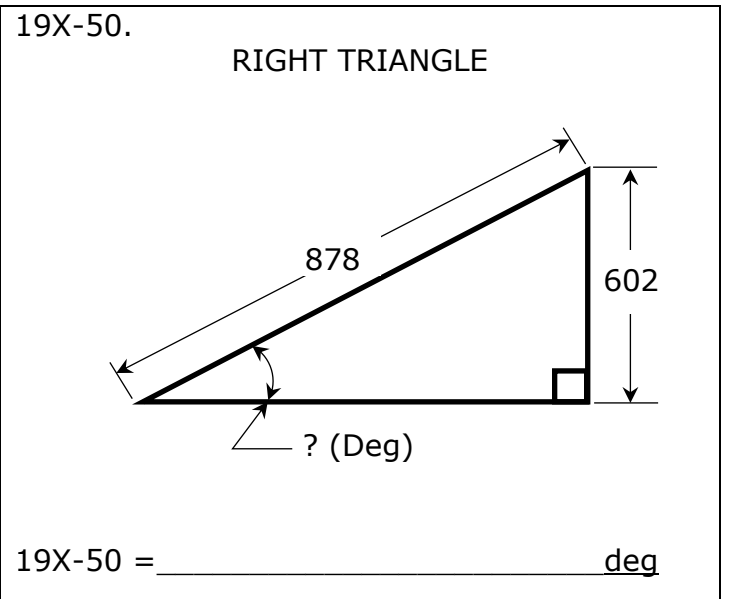
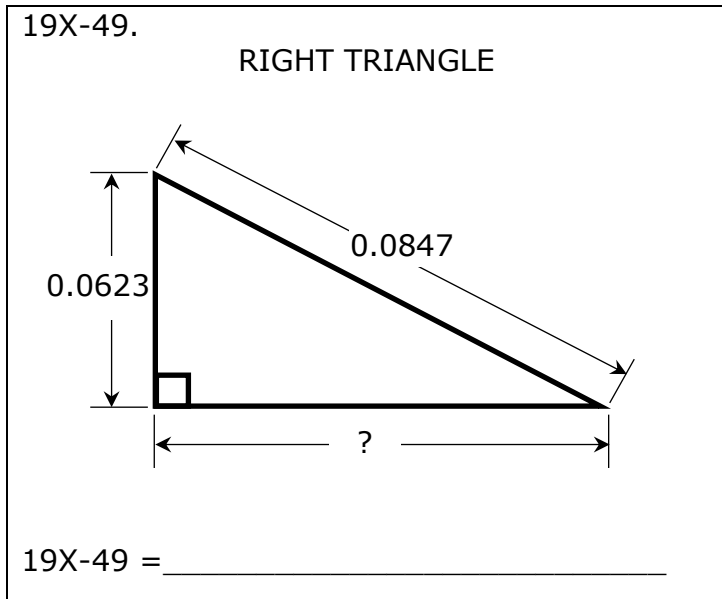

19X-51. $\frac{\sqrt{8.45 + \pi + 8.29}}{(0.135 - 0.222 + 0.229)^4}$ -----51= _____

19X-52. $\left[\frac{\sqrt{\sqrt{2370 - 1310}}}{-(24500 - 10600)} \right]^2 [1570 + 753]$ -----52= _____

19X-53. $\left[\frac{31.1 - 10.5 + \sqrt{1270/9.08}}{-5770 + 8340} \right]^{-4}$ -----53= _____

19X-54. $\sqrt{\frac{(12300)(48800)}{(21400)(6.96 \times 10^5)}} - 0.0364 + 0.143$ -----54= _____

19X-55. $(120)^2 \sqrt{(149)/(394)} - (8340 + 4550)$ -----55= _____

19X-56. $\sqrt{\frac{1/(20.5 - 4.49)}{(9.81)(312 + 396)^2}}$ -----56= _____

19X-57. $\sqrt{\frac{(236)(1110)}{(1060) + (1070)}} + 1/(0.618)^5$ -----57= _____

19X-58. $(\text{deg}) \tan(1200^\circ) + (48.1/50.6)$ -----58= _____

19X-59. Assuming a constant humidity and pressure, the speed of sound varies with temperature. Under these conditions, the speed of sound increases or decreases six-tenths of a meter/sec for every degree Celsius change. If the speed of sound at 0°C at a certain location is 341 meters/sec (m/s), what is the speed of sound at the same location but at the temperature of 100° Fahrenheit? -----59= _____ m/s

19X-60. Under certain conditions the loudness of sound (sound intensity) is inversely proportional to the square of the distance from the source of the sound. If a firecracker makes a sound of 45 decibels (dB), how loud is the sound 4.75 meters away? -----60= _____ dB

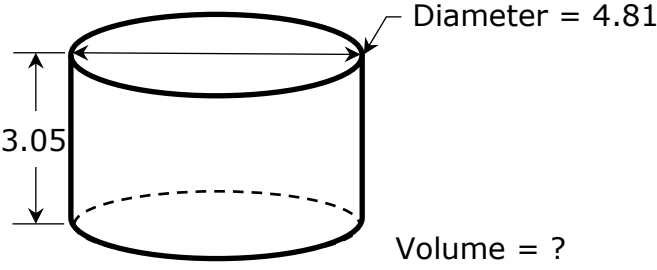
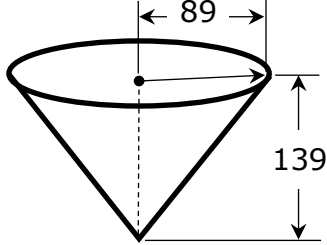
<p>19X-61. RIGHT CYLINDER</p>  <p style="text-align: right;">Volume = ?</p> <p>19X-61 = _____</p>	<p>19X-62. RIGHT CONE</p>  <p style="text-align: center;">Volume = ?</p> <p>19X-62 = _____</p>
---	--

19X-63. $\frac{24! + 23!}{25!}$ -----63= _____

19X-64. $(2.32 \times 10^9 - 2.55 \times 10^9)^5 (4.93 \times 10^7)$ -----64= _____

19X-65. (deg) $\frac{\cos(223^\circ)}{430}$ -----65= _____

19X-66. (deg) $\sin(60.4^\circ - 30.5^\circ) + 0.197$ -----66= _____

19X-67. (deg) $(3790 - 2220)\sin(4.38^\circ) + 89.1$ -----67= _____

19X-68. (rad) $\tan[(1.76 - 0.28)(0.773)]$ -----68= _____

19X-69. (rad) $(525)\tan(61.8)$ -----69= _____

19X-70. $(7470 - 5110)^{0.176 - 0.339}$ -----70= _____

19X-71. A number multiplied by the quantity, itself increased by pi, is equal to 10. What is the positive value for this number? -----71= _____

19X-72. A city in the north Texas area increased in population from 2,472 to 12,019 in a period of 5 years. What is the percent increase? --72= _____ %

19X-73.
 SQUARE & ISOSCELES TRIANGLE

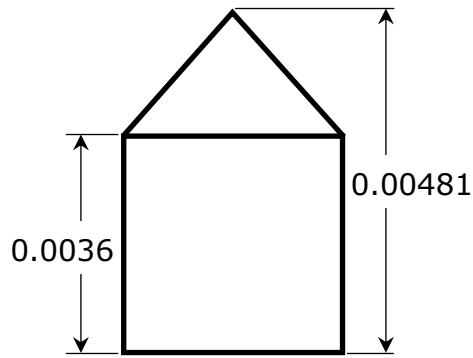

Total Area = ?

19X-73 = _____

19X-74.
 CONCENTRIC HEMISPHERES

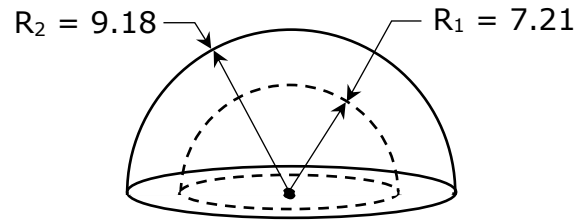

Volume Between = ?

19X-74 = _____

19X-75. $\ln\left[\frac{66.2 + 84.3 + 69.8}{32.9 + 133 - 123}\right]$ -----75= _____

19X-76. $\frac{\log(6.34 \times 10^6 + 6.11 \times 10^6)}{3.24}$ -----76= _____

19X-77. $\log\sqrt{\frac{212 - 173}{(1.08)(60.4)}}$ -----77= _____

19X-78. $(0.366)^\pi (130)^2 (14.1 - 9.98)^3$ -----78= _____

19X-79. $1 + 3 + 5 + \dots + 279$ -----79= _____

19X-80. $1 + (0.379) + \frac{(0.379)^2}{2} + \frac{(0.379)^3}{6} + \frac{(0.379)^4}{24}$ -----80= _____

2019 University Interscholastic League MS/JH Calculator Contest A Answer Key

$$\begin{aligned} 19X-1 &= -115 \\ &= -1.15 \times 10^2 \end{aligned}$$

$$\begin{aligned} 19X-2 &= -51.0 \\ &= -5.10 \times 10^1 \end{aligned}$$

$$\begin{aligned} 19X-3 &= 4.59 \\ &= 4.59 \times 10^0 \end{aligned}$$

$$\begin{aligned} 19X-4 &= -0.858 \\ &= -8.58 \times 10^{-1} \end{aligned}$$

$$\begin{aligned} 19X-5 &= -3450 \\ &= -3.45 \times 10^3 \end{aligned}$$

$$\begin{aligned} 19X-6 &= 180 \\ &= 1.80 \times 10^2 \end{aligned}$$

$$\begin{aligned} 19X-7 &= 6.61 \\ &= 6.61 \times 10^0 \end{aligned}$$

$$\begin{aligned} 19X-8 &= -4.38 \\ &= -4.38 \times 10^0 \end{aligned}$$

$$19X-9 = 1.54 \times 10^6$$

$$19X-10 = 1.33 \times 10^{10}$$

$$\begin{aligned} 19X-11 &= 19.5 \\ &= 1.95 \times 10^1 \end{aligned}$$

$$\begin{aligned} 19X-12 &= 148 \\ &= 1.48 \times 10^2 \end{aligned}$$

$$\begin{aligned} 19X-13 &= 283 \\ &= 2.83 \times 10^2 \end{aligned}$$

$$19X-14 = 3.60 \times 10^7$$

$$\begin{aligned} 19X-15 &= 27.2 \\ &= 2.72 \times 10^1 \end{aligned}$$

$$\begin{aligned} 19X-16 &= 0.0846 \\ &= 8.46 \times 10^{-2} \end{aligned}$$

$$\begin{aligned} 19X-17 &= 11.1 \\ &= 1.11 \times 10^1 \end{aligned}$$

$$\begin{aligned} 19X-18 &= -26.6 \\ &= -2.66 \times 10^1 \end{aligned}$$

$$\begin{aligned} 19X-19 &= -0.590 \\ &= -5.90 \times 10^{-1} \end{aligned}$$

$$\begin{aligned} 19X-20 &= 2.99 \\ &= 2.99 \times 10^0 \end{aligned}$$

$$\begin{aligned} 19X-21 &= 0.0234 \\ &= 2.34 \times 10^{-2} \end{aligned}$$

$$\begin{aligned} 19X-22 &= 16.0 \\ &= 1.60 \times 10^1 \end{aligned}$$

$$\begin{aligned} 19X-23 &= 452 \\ &= 4.52 \times 10^2 \end{aligned}$$

$$\begin{aligned} 19X-24 &= 21.9 \\ &= 2.19 \times 10^1 \end{aligned}$$

$$19X-25 = 65$$

INTEGER

$$19X-26 = 76.32$$

Dollar Answer

$$19X-27 = -7.14 \times 10^6$$

$$19X-28 = 3.62 \times 10^{-12}$$

$$\begin{aligned} 19X-29 &= 722 \\ &= 7.22 \times 10^2 \end{aligned}$$

$$19X-30 = 4.63 \times 10^{12}$$

$$19X-31 = 1.30 \times 10^{-13}$$

$$\begin{aligned} 19X-32 &= 1.14 \\ &= 1.14 \times 10^0 \end{aligned}$$

$$\begin{aligned} 19X-33 &= 0.0123 \\ &= 1.23 \times 10^{-2} \end{aligned}$$

$$\begin{aligned} 19X-34 &= 1.23 \\ &= 1.23 \times 10^0 \end{aligned}$$

$$\begin{aligned} 19X-35 &= 33000 \\ &= 3.30 \times 10^4 \end{aligned}$$

$$\begin{aligned} 19X-36 &= 31.5 \\ &= 3.15 \times 10^1 \end{aligned}$$

$$\begin{aligned} 19X-37 &= 124 \\ &= 1.24 \times 10^2 \end{aligned}$$

$$\begin{aligned} 19X-38 &= 0.113 \\ &= 1.13 \times 10^{-1} \end{aligned}$$

2019 University Interscholastic League MS/JH Calculator Contest A Answer Key

19X-39 = 2.63 = 2.63×10^0	19X-51 = 11000 = 1.10×10^4	19X-61 = 55.4 = 5.54×10^1	19X-73 = 0.0000151 = 1.51×10^{-5}
19X-40 = 3540 = 3.54×10^3	19X-52 = 0.000391 = 3.91×10^{-4}	19X-62 = 1.15×10^6	19X-74 = 835 = 8.35×10^2
19X-41 = 1.50×10^{10}	19X-53 = 3.95×10^7	19X-63 = 0.0417 = 4.17×10^{-2}	19X-75 = 1.64 = 1.64×10^0
19X-42 = 5.90×10^{14}	19X-54 = 0.307 = 3.07×10^{-1}	19X-64 = -3.17×10^{49}	19X-76 = 2.19 = 2.19×10^0
19X-43 = 0.104 = 1.04×10^{-1}	19X-55 = -4030 = -4.03×10^3	19X-65 = -0.00170 = -1.70×10^{-3}	19X-77 = -0.112 = -1.12×10^{-1}
19X-44 = 63000 = 6.30×10^4	19X-56 = 0.000113 = 1.13×10^{-4}	19X-66 = 0.695 = 6.95×10^{-1}	19X-78 = 50300 = 5.03×10^4
19X-45 = 5.82 = 5.82×10^0	19X-57 = 22.2 = 2.22×10^1	19X-67 = 209 = 2.09×10^2	19X-79 = 19600 = 1.96×10^4
19X-46 = 0.0348 = 3.48×10^{-2}	19X-58 = -0.781 = -7.81×10^{-1}	19X-68 = 2.20 = 2.20×10^0	19X-80 = 1.46 = 1.46×10^0
19X-47 = 0.334 = 3.34×10^{-1}	19X-59 = 364 = 3.64×10^2	19X-69 = -878 = -8.78×10^2	
19X-48 = 0.102 = 1.02×10^{-1}	19X-60 = 1.99 = 1.99×10^0	19X-70 = 0.282 = 2.82×10^{-1}	
19X-49 = 0.0574 = 5.74×10^{-2}		19X-71 = 1.96 = 1.96×10^0	
19X-50 = 43.3 = 4.33×10^1		19X-72 = 386 = 3.86×10^2	

FALL/WINTER DISTRICT 2018-2019

A+ ACADEMICS



University Interscholastic League

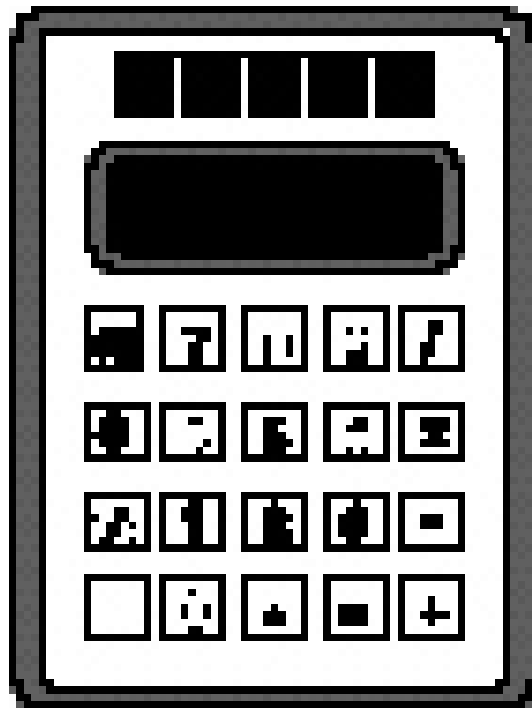

Calculator Applications

**DO NOT OPEN TEST
UNTIL TOLD TO DO SO**

How to Write the Answers

A. For all problems except stated problems as noted below—write three significant digits.

1. Examples (* means correct but not recommended)

Correct: 12.3, 123, 123.*, 1.23x10*, 1.23x10^{0*}
1.23x10¹, 1.23x10⁰¹, .0190, 0.0190, 1.90x10⁻²

Incorrect: 12.30, 123.0, 1.23(10)², 1.23·10², 1.230x10²,
1.23*10², 0.19, 1.9x10⁻², 19.0x10⁻³, 1.90E-02,

answers written in parentheses(), brackets[] or braces{} are incorrect

2. Plus or minus one digit error in the third significant digit is permitted.

B. For stated problems

1. Except for integer and dollar sign problems, answers to stated problems should be written with three significant digits.

2. Integer problems are indicated by (integer) in the answer blank. Integer problems answers must be exact, no plus or minus one digit, no decimal point or scientific notation.

3. Dollar sign (\$) problems should be answered to the exact cent, but plus or minus one cent error is permitted. Answers must be in fixed notation. The decimal point and cents are required for exact-dollar answers.

2019 University Interscholastic League MS/JH Calculator Contest B

19Y-1. $-815 - 309$ ----- 1= _____

19Y-2. $45 - 25 + 31$ ----- 2= _____

19Y-3. $87 + 39 - 36$ ----- 3= _____

19Y-4. $\pi - 14 - 8 + 16$ ----- 4= _____

19Y-5. $1560 - 4510 - 4210 + 6060$ ----- 5= _____

19Y-6. $202 - 176 - 54.5 - 139 + 244$ ----- 6= _____

19Y-7. $(3.17 - 1.24) + (0.642 - 1.25 - 2.11)$ ----- 7= _____

19Y-8. $5.62 + 2.98 + 7.19 + \pi + 1.18$ ----- 8= _____

19Y-9. $344 \times 51.7 \times 52.1$ ----- 9= _____

19Y-10. $1670 \times 22.1 \times 5000 \times 31.3$ ----- 10= _____

19Y-11. What is the sum of 16.4, pi, and positive square root of 29? 11= _____

19Y-12. A rectangular block of wood has a mass of 83 grams and a volume of 92 cm^3 . What is the wood's density? ----- 12= _____ g/cm^3

19Y-13. A car has a miles per gallon (mpg) rating of 27.6 mpg. How many miles will the car travel on 16.3 gallons of fuel? ----- 13= _____ miles

19Y-14. $(224)[85 \times 79 \times 455]$ ----- 14= _____

19Y-15. $(81)[116 \times 84/16]$ ----- 15= _____

19Y-16. $\left[\frac{555}{122}\right] [(585/149) - 2.67]$ ----- 16= _____

19Y-17. $(203 + 504)[120 - 346 - 323]$ ----- 17= _____

19Y-18. $\left[\frac{(8950/7120) - (6200/1920)}{0.398/(0.699)}\right]$ ----- 18= _____

19Y-19. $\frac{(57/112) + (190/183)}{(6.70 \times 10^{-4} - 9.34 \times 10^{-4})}$ ----- 19= _____

19Y-20. $(\pi)[310/413 \times 545/344] - 1.47$ ----- 20= _____

19Y-21. $\frac{(\pi)(2/13)(2/14)}{59}$ ----- 21= _____

19Y-22. $\frac{(\pi + 3.17 - 2.79)}{\{(0.00224 - 0.00966)/(856)\}}$ ----- 22= _____

19Y-23. $\left[\frac{465 + 359}{839 - 1320}\right] \left[\frac{583}{1430}\right]$ ----- 23= _____

19Y-24. According to my car's temperature probe, the outside temperature was 98°F. The actual outside air temperature was 92.5°F. What is the percent error in the probe's temperature reading?----- 24= _____ %

19Y-25. I bought a box of cat litter that was priced at \$19.79. If I used a \$2-off coupon and sale tax is 8¼%, how much did the cat litter cost? 25=\$ _____

19Y-26. If there are 640 acres in one square mile, how many square feet are in one acre? ----- 26= _____ ft²(Integer)

19Y-27. $(0.00196) \left[\left[\frac{0.00149}{(3.82 \times 10^{-4})} \right] \left[\frac{211}{(122)} \right] \right]$ ----- 27= _____

19Y-28. $(682) \left[\left(\frac{64.4}{67.3} \right) (118 + 49) \right]$ ----- 28= _____

19Y-29. $[6050 - (5710 + 4470)] + [(14.2)(826 - 1000)]$ ----- 29= _____

19Y-30. $\frac{(0.0305 + 0.0813)}{(9.91 \times 10^{10})}$ ----- 30= _____

19Y-31. $(68) \left[(7.94 \times 10^9) - (3.74 \times 10^{10}) \right]$ ----- 31= _____

19Y-32. $(0.0123) \left[\frac{0.249}{(3.77 \times 10^7)} \right]$ ----- 32= _____

19Y-33. $\frac{1}{21.8} - \frac{1}{(50.7 + 123)}$ ----- 33= _____

19Y-34. $\left[\frac{1/475}{1/510} \right] + [0.407]$ ----- 34= _____

19Y-35. In Mackenzie's gym class there are 28 boys and 23 girls. If every day the teacher randomly chooses one student to take the roll sheet to the attendance office, what is the probability that it will be a girl? ---- 35= _____

19Y-36. A 10-foot ladder is leaned up against a building wall. If the bottom of the ladder is on level ground and 3 ft 8 in from the bottom of the wall, how far up the wall is the top of the ladder? ----- 36= _____ ft

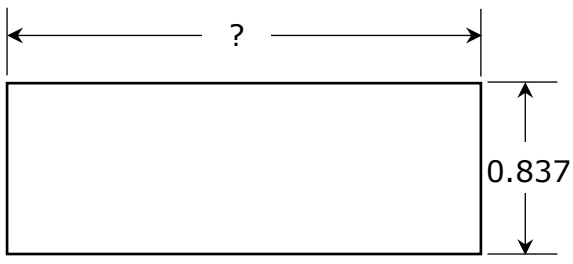
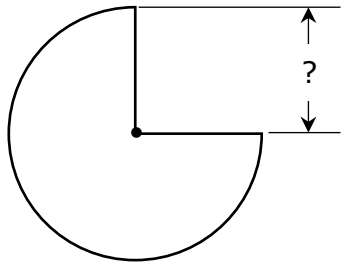
<p>19Y-37. RECTANGLE</p>  <p style="text-align: center;">Perimeter = 5.25</p> <p>19Y-37= _____</p>	<p>19Y-38. THREE-QUARTERS CIRCLE</p>  <p style="text-align: center;">Area = 500</p> <p>19Y-38= _____</p>
--	--

19Y-39. $\left[\frac{221}{2.89}\right](0.289 + 0.992)^4$ ----- 39= _____

19Y-40. $\sqrt[4]{\frac{17.4 + 4.49}{5240 - 1900}}$ ----- 40= _____

19Y-41. $\frac{(15000 + 19100)^3}{(0.0819 - 0.0772)^2}$ ----- 41= _____

19Y-42. $\sqrt{(31.5/11.4) + 1.93 - 0.657}$ ----- 42= _____

19Y-43. $(35500)\sqrt{7680 + 1830 + 8610}$ ----- 43= _____

19Y-44. $(1/\pi)\sqrt[3]{\frac{0.139 + 0.124}{0.0471 - 0.0211}}$ ----- 44= _____

19Y-45. $\frac{1}{\sqrt{436 + 1060 + 372}} + \left(\frac{1}{\sqrt{5.46}}\right)^3$ ----- 45= _____

19Y-46. $\sqrt[3]{2.06 - 2990/4710} + 1/\sqrt{0.29 + 0.191}$ ----- 46= _____

19Y-47. A steel pipe, 16 inches in diameter, stretches from Cushing, Oklahoma to Houston, Texas; a distance of 511 miles. If the pipe is filled with natural gas, how much gas is in the pipe? ----- 47= _____ cu.ft.

19Y-48. Liz found out that a company charges \$250 plus \$7.75 per person to host a birthday party for one of her sons. If there were a total of 18 individuals at the party, how much did it cost? ----- 48=\$ _____

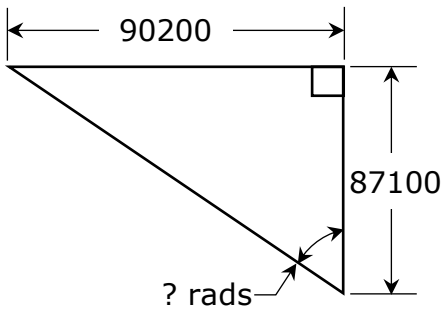
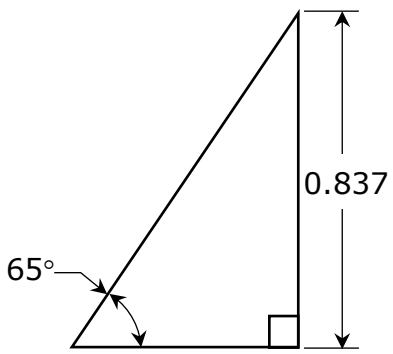
<p>19Y-49. RIGHT TRIANGLE</p>  <p>19Y-49= _____ rads</p>	<p>19Y-50. RIGHT TRIANGLE</p>  <p>19Y-50= _____</p>
--	--

19Y-51. $\frac{(0.00822 + 0.00484 - 0.00149)^2}{\sqrt{0.0392 + 0.291 + 0.31}}$ ----- 51= _____

19Y-52. $\sqrt{\frac{7.83 \times 10^{-5}}{(0.24)(890)} + \frac{(0.042 - 0.0335)}{(5.51 + 4.71)}}$ ----- 52= _____

19Y-53. $\left[\frac{5.09 - 3.32 + \sqrt{2.49/1.71}}{-198 + 326} \right]^{-2}$ ----- 53= _____

19Y-54. $\sqrt{\frac{(11900)(41100)}{(50600)(2850)}} - 0.786 + 0.202$ ----- 54= _____

19Y-55. $21200 + \sqrt{(18400)(21400)} - (6870 + 3750)$ ----- 55= _____

19Y-56. $0.969 + \sqrt{(1970)/(1480)} - (0.511 + 0.639)^2$ ----- 56= _____

19Y-57. $\sqrt{\frac{1/(17.9 - 16.6)}{(194)(17.9 + 4.79)^{-2}}}$ ----- 57= _____

19Y-58. $\sqrt{\frac{(29.9)(86.5)}{(217) + (123)}} - 2.92$ ----- 58= _____

19Y-59. A formula for calculating the final speed of an object dropping in a gravitational field is found by adding the initial speed to the product of the value of the acceleration due to gravity and the time for that acceleration. An object is thrown downward with an initial speed of 4.75 feet/second on the airless Moon where the acceleration due to gravity is 5.36 feet/second². If the object takes 2.83 seconds to land, what is the speed of the object upon landing? ----- 59= _____ ft/sec

19Y-60. An equation, studied by many high school Physics students, is called the lens equation. It states that the reciprocal of the focal length of a lens is equal to the sum of the reciprocal of the object distance and the reciprocal of the image distance. If the focal length of a lens is 35 millimeters and the image distance is 36 millimeters, what is the object distance? ----- 60= _____ meters

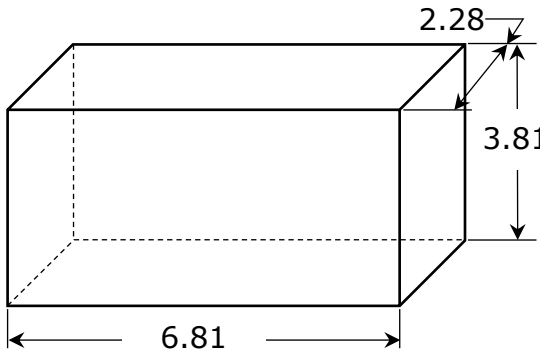
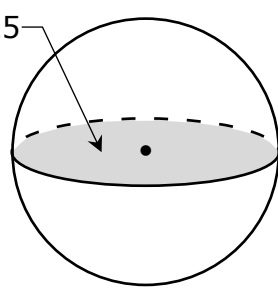
<p>19Y-61. RECTANGULAR BOX</p>  <p style="text-align: center;">Total Surface Area = ?</p> <p>19Y-61= _____</p>	<p>19Y-62. SPHERE</p>  <p style="text-align: center;">Volume = ?</p> <p>19Y-62= _____</p>
--	---

19Y-63. $\frac{6! - 8!}{14!}$ ----- 63= _____

19Y-64. (deg) $(157 - 261)\tan(933^\circ)$ ----- 64= _____

19Y-65. $(106 - \pi)e^{0.379}$ ----- 65= _____

19Y-66. (rad) $\sin\left[\frac{(4.2)(\pi)}{(50.1)(2.61)}\right]$ ----- 66= _____

19Y-67. (deg) $\tan(1.74^\circ - 0.351^\circ) + 0.00383$ ----- 67= _____

19Y-68. (deg) $\frac{\sin(49.4^\circ) - \tan(49.4^\circ)}{\sin(49.4^\circ)}$ ----- 68= _____

19Y-69. (deg) $\frac{\sin(5.61^\circ)}{\tan(5.61^\circ)}[622]$ ----- 69= _____

19Y-70. $(16.5 + 54.3 + 43.1)^{2/5}$ ----- 70= _____

19Y-71. The international Space Station (ISS) is currently 211 miles above the Earth's surface. If the radius of the Earth is 3960 miles and the ISS take 93 minutes to circle once around in orbit, how fast is the ISS moving in orbit around the Earth?----- 71= _____ mph

19Y-72. If a light beam travels with the speed of 186,000 miles/second, how long does it take to travel 132 feet across a gym floor? ----- 72= _____ s

19Y-73.

SQUARE AND RECTANGLE

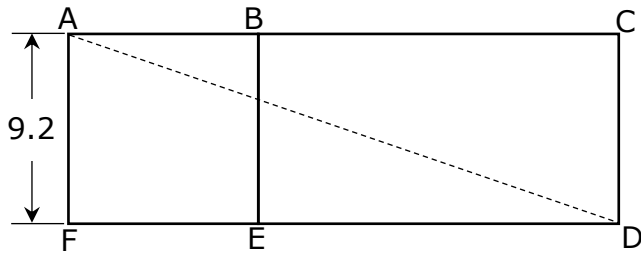

Rectangle Area = 2.1 x Square Area

AD = ?

19Y-73= _____

19Y-74.

CUBE AND RIGHT CYLINDER CAVITY

Shaded Area = 3.95×10^9

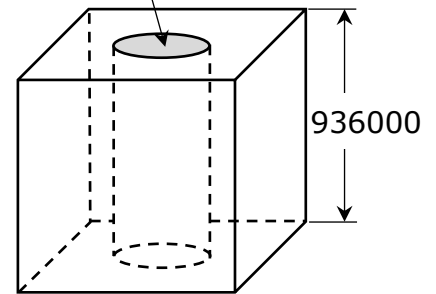

Volume Remaining = ?

19Y-74= _____

19Y-75. $\frac{\text{Log}(7.78 \times 10^{10} + 5.50 \times 10^{11})}{0.514}$ ----- 75= _____

19Y-76. $\frac{(6.48)^{0.686}(48.2)^{0.986}}{(9.17 - 5.3)^{-10}}$ ----- 76= _____

19Y-77. $(9010)_{10}^{(0.388)}(3.51)$ ----- 77= _____

19Y-78. $(7.39)^\pi(0.0301)^2(415 - 276)^4$ ----- 78= _____

19Y-79. $1 + 2 + 3 + \dots + 539$ ----- 79= _____

19Y-80. $1 + 0.16 + (0.16)^2 + \frac{(0.16)^4}{8} - \frac{(0.16)^5}{15}$ ----- 80= _____

2019 University Interscholastic League MS/JH Calculator Contest B Answer Key

$$\begin{aligned} 19Y-1 &= -1120 \\ &= -1.12 \times 10^3 \end{aligned}$$

$$\begin{aligned} 19Y-2 &= 51.0 \\ &= 5.10 \times 10^1 \end{aligned}$$

$$\begin{aligned} 19Y-3 &= 90.0 \\ &= 9.00 \times 10^1 \end{aligned}$$

$$\begin{aligned} 19Y-4 &= -2.86 \\ &= -2.86 \times 10^0 \end{aligned}$$

$$\begin{aligned} 19Y-5 &= -1100 \\ &= -1.10 \times 10^3 \end{aligned}$$

$$\begin{aligned} 19Y-6 &= 76.5 \\ &= 7.65 \times 10^1 \end{aligned}$$

$$\begin{aligned} 19Y-7 &= -0.788 \\ &= -7.88 \times 10^{-1} \end{aligned}$$

$$\begin{aligned} 19Y-8 &= 20.1 \\ &= 2.01 \times 10^1 \end{aligned}$$

$$\begin{aligned} 19Y-9 &= 927000 \\ &= 9.27 \times 10^5 \end{aligned}$$

$$19Y-10 = 5.78 \times 10^9$$

$$\begin{aligned} 19Y-11 &= 24.9 \\ &= 2.49 \times 10^1 \end{aligned}$$

$$\begin{aligned} 19Y-12 &= 0.902 \\ &= 9.02 \times 10^{-1} \end{aligned}$$

$$\begin{aligned} 19Y-13 &= 450 \\ &= 4.50 \times 10^2 \end{aligned}$$

$$19Y-14 = 6.84 \times 10^8$$

$$\begin{aligned} 19Y-15 &= 49300 \\ &= 4.93 \times 10^4 \end{aligned}$$

$$\begin{aligned} 19Y-16 &= 5.71 \\ &= 5.71 \times 10^0 \end{aligned}$$

$$\begin{aligned} 19Y-17 &= -388000 \\ &= -3.88 \times 10^5 \end{aligned}$$

$$\begin{aligned} 19Y-18 &= -3.46 \\ &= -3.46 \times 10^0 \end{aligned}$$

$$\begin{aligned} 19Y-19 &= -5860 \\ &= -5.86 \times 10^3 \end{aligned}$$

$$\begin{aligned} 19Y-20 &= 2.27 \\ &= 2.27 \times 10^0 \end{aligned}$$

$$\begin{aligned} 19Y-21 &= 0.00117 \\ &= 1.17 \times 10^{-3} \end{aligned}$$

$$\begin{aligned} 19Y-22 &= -406000 \\ &= -4.06 \times 10^5 \end{aligned}$$

$$\begin{aligned} 19Y-23 &= -0.698 \\ &= -6.98 \times 10^{-1} \end{aligned}$$

$$\begin{aligned} 19Y-24 &= 5.95 \\ &= 5.95 \times 10^0 \end{aligned}$$

$$19Y-25 = 19.26$$

Dollar Answer

$$19Y-26 = 43560$$

Integer Answer

$$\begin{aligned} 19Y-27 &= 0.0132 \\ &= 1.32 \times 10^{-2} \end{aligned}$$

$$\begin{aligned} 19Y-28 &= 109000 \\ &= 1.09 \times 10^5 \end{aligned}$$

$$\begin{aligned} 19Y-29 &= -6600 \\ &= -6.60 \times 10^3 \end{aligned}$$

$$19Y-30 = 1.13 \times 10^{-12}$$

$$19Y-31 = -2.00 \times 10^{12}$$

$$19Y-32 = 8.12 \times 10^{-11}$$

$$\begin{aligned} 19Y-33 &= 0.0401 \\ &= 4.01 \times 10^{-2} \end{aligned}$$

$$\begin{aligned} 19Y-34 &= 1.48 \\ &= 1.48 \times 10^0 \end{aligned}$$

$$\begin{aligned} 19Y-35 &= 0.451 \\ &= 4.51 \times 10^{-1} \end{aligned}$$

$$\begin{aligned} 19Y-36 &= 9.30 \\ &= 9.30 \times 10^0 \end{aligned}$$

$$\begin{aligned} 19Y-37 &= 1.79 \\ &= 1.79 \times 10^0 \end{aligned}$$

$$\begin{aligned} 19Y-38 &= 14.6 \\ &= 1.46 \times 10^1 \end{aligned}$$

2019 University Interscholastic League MS/JH Calculator Contest B Answer Key

19Y-39	= 206	19Y-51	= 0.000167	19Y-61	= 100	19Y-73	= 30.0
	= 2.06×10^{-2}		= 1.67×10^{-4}		= 1.00×10^{-2}		= 3.00×10^{-1}
19Y-40	= 0.285	19Y-52	= 0.00144	19Y-62	= 0.000564	19Y-74	= 8.16×10^{17}
	= 2.85×10^{-1}		= 1.44×10^{-3}		= 5.64×10^{-4}	19Y-75	= 23.0
19Y-41	= 1.80×10^{18}	19Y-53	= 1850	19Y-63	= -4.54×10^{-7}		= 2.30×10^1
19Y-42	= 2.01		= 1.85×10^3	19Y-64	= -67.5	19Y-76	= 1.24×10^8
	= 2.01×10^0	19Y-54	= 1.26		= -6.75×10^1		
19Y-43	= 4.78×10^6		= 1.26×10^0	19Y-65	= 150	19Y-77	= 207000
		19Y-55	= 30400		= 1.50×10^2		= 2.07×10^5
19Y-44	= 0.688		= 3.04×10^4	19Y-66	= 0.101	19Y-78	= 1.81×10^8
	= 6.88×10^{-1}	19Y-56	= 0.800		= 0.0281		
19Y-45	= 0.102		= 8.00×10^{-1}	19Y-67	= 0.0281	19Y-79	= 146000
	= 1.02×10^{-1}	19Y-57	= 1.43		= -0.537		= 1.46×10^5
19Y-46	= 2.57		= 1.43×10^0	19Y-68	= -0.537	19Y-80	= 1.19
	= 2.57×10^0				= -5.37×10^{-1}		= 1.19×10^0
19Y-47	= 3.77×10^6	19Y-58	= -0.162	19Y-69	= 619		
			= -1.62×10^{-1}				
19Y-48	= 389.50	19Y-59	= 19.9		= 6.19×10^2		
	Dollar Answer			19Y-70	= 6.65		
19Y-49	= 0.803		= 19.9		= 6.65×10^0		
	= 8.03×10^{-1}	19Y-60	= 1.99×10^1	19Y-71	= 16900		
19Y-50	= 0.163		= 1.26		= 1.69×10^4		
	= 1.63×10^{-1}		= 1.26×10^0	19Y-72	= 1.34×10^{-7}		

SPRING DISTRICT 2018-2019

A+ ACADEMICS



University Interscholastic League

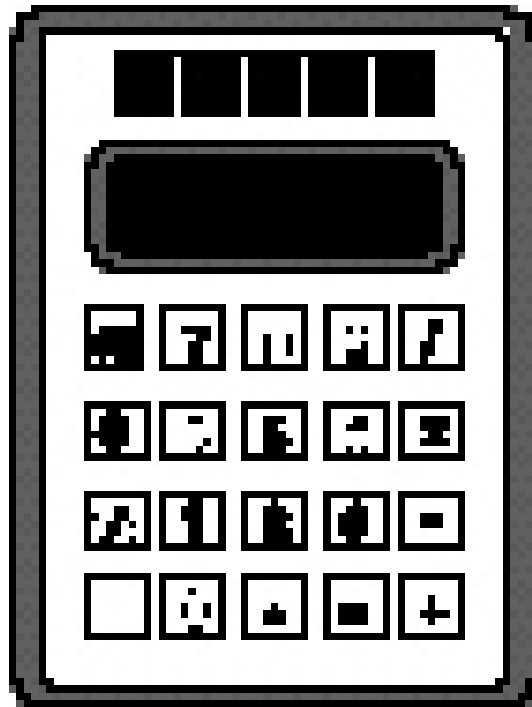

Calculator Applications

**DO NOT OPEN TEST
UNTIL TOLD TO DO SO**

How to Write the Answers

A. For all problems except stated problems as noted below—write three significant digits.

1. Examples (* means correct but not recommended)

Correct: 12.3, 123, 123.*, 1.23x10*, 1.23x10^{0*}
1.23x10¹, 1.23x10⁰¹, .0190, 0.0190, 1.90x10⁻²

Incorrect: 12.30, 123.0, 1.23(10)², 1.23·10², 1.230x10²,
1.23*10², 0.19, 1.9x10⁻², 19.0x10⁻³, 1.90E-02,

answers written in parentheses(), brackets[] or braces{} are incorrect

2. Plus or minus one digit error in the third significant digit is permitted.

B. For stated problems

1. Except for integer and dollar sign problems, answers to stated problems should be written with three significant digits.

2. Integer problems are indicated by (integer) in the answer blank. Integer problems answers must be exact, no plus or minus one digit, no decimal point or scientific notation.

3. Dollar sign (\$) problems should be answered to the exact cent, but plus or minus one cent error is permitted. Answers must be in fixed notation. The decimal point and cents are required for exact-dollar answers.

2019 University Interscholastic League MS/JH Calculator Contest C

19Z-1. $643 - 1110$ ----- 1= _____

19Z-2. $15 + 34 - 60$ ----- 2= _____

19Z-3. $-2700 - 1660 + 3670$ ----- 3= _____

19Z-4. $\pi - 27 - 25 - 17$ ----- 4= _____

19Z-5. $-52 + 146 - 177 - 355$ ----- 5= _____

19Z-6. $134 - 81.6 - 59.5 + 137 + 169$ ----- 6= _____

19Z-7. $-0.281 + 1.14 - 0.608 + 1.34 + 0.452$ ----- 7= _____

19Z-8. $0.19 - 1.33 + 1.37 - 1.24 - 0.802$ ----- 8= _____

19Z-9. $142 \times 117 \times 213$ ----- 9= _____

19Z-10. $187 \times 1180 \times 208 \times 933$ ----- 10= _____

19Z-11. What is the positive difference between two pi and $\frac{13}{7}$? ----- 11= _____

19Z-12. A rectangular block of wood has a mass of 79.3 grams and a volume of 90 cm³. What is the wood's density? ----- 12= _____ g/cm³

19Z-13. A car has a mile per gallon (mpg) rating of 31.6 mpg. How many miles will the car travel on 16.5 gallons of fuel? ----- 13= _____ miles

19Z-14. $(-77)[131 \times 71 \times 66]$ -----14= _____

19Z-15. $(-217)[89 \times 189/135]$ -----15= _____

19Z-16. $\{52/45\} \left[\frac{311}{300 + 47} \right]$ -----16= _____

19Z-17. $\left[\frac{73}{51} \right] [(27/13) + 0.785]$ -----17= _____

19Z-18. $\frac{[0.109/(0.165)]/0.709}{(6.65 \times 10^{-4} \times 4.84 \times 10^{-4})(1.12)}$ -----18= _____

19Z-19. $\left[\frac{68/59}{134/101} \right] \{0.327 + 0.229 - 1.6\}$ -----19= _____

19Z-20. $(1.55)[68/132 \times 232/212] - 0.728$ -----20= _____

19Z-21. $\frac{(1440)(282)}{0.0176} (0.00117 - 0.00108)$ -----21= _____

19Z-22. $\frac{(\pi)(87/113)(95/67)}{(41/124)}$ -----22= _____

19Z-23. $\left[\frac{760 + 4610}{1880 - 4090} \right] \left[\frac{5020}{2530} \right]$ -----23= _____

19Z-24. According to my car's temperature probe, the outside temperature was 67°F. The actual outside air temperature was 66.5°F. What is the percent error in the probe's temperature reading? -----24= _____ %

19Z-25. I bought a box of cat litter that was priced at \$17.99. If I used a \$2-off coupon and sale tax is 8¼%, how much did the cat litter cost? -25=\$ _____

19Z-26. If there are 640 acres in one square mile, how many square yards (yds) are in one acre? -----26= _____ yds²(Integer)

19Z-27. $[1930 - (472 + 1840)] + [(0.381)(1570 - 1850)]$ -----27= _____

19Z-28. $(0.00331)[[5.4/(4.56)][0.0284/(0.0172)]]$ -----28= _____

19Z-29. $\frac{(35.4 - 36.9)(0.0093 + 0.0126)}{(1.61 \times 10^{11})}$ -----29= _____

19Z-30. $\frac{(0.0202 + 0.0219)}{(7.00 \times 10^{11})}$ -----30= _____

19Z-31. $\frac{1}{501} + \frac{1}{(468 - 270)}$ -----31= _____

19Z-32. $[0.0297] \left[\frac{1/4570}{1/(5050)} \right]$ -----32= _____

19Z-33. $\frac{1}{253} - \frac{1}{(346 + 288)}$ -----33= _____

19Z-34. $\frac{1}{173} - \frac{1}{115} + \frac{1}{26.6}$ -----34= _____

19Z-35. In Mackenzie's gym class there are 32 boys and 24 girls. If every day the teacher randomly chooses one student to take the roll sheet to the attendance office, what is the probability that it will be a girl? ----35= _____

19Z-36. A 12-foot ladder is leaned up against a building wall. If the bottom of the ladder is on level ground and 3 ft 8 in from the bottom of the wall, how far up the wall is the top of the ladder? -----36= _____ ft

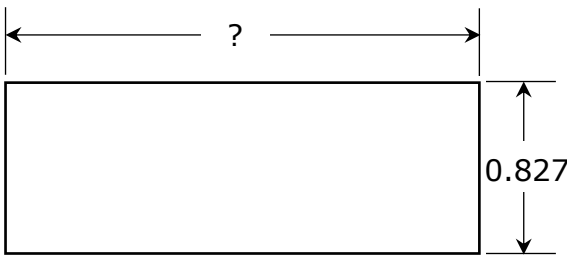
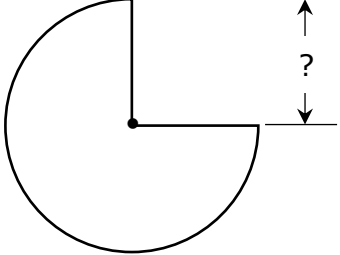
<p>19Z-37.</p> <p style="text-align: center;">RECTANGLE</p>  <p style="text-align: center;">Perimeter = 5.45</p> <p>19Z-37= _____</p>	<p>19Z-38.</p> <p style="text-align: center;">THREE-QUARTERS CIRCLE</p>  <p style="text-align: center;">Area = 0.846</p> <p>19Z-38= _____</p>
--	--

19Z-39. $\left[\frac{1780 + (1/(0.00229))}{(1700/494) - 2.79} \right]^2$ -----39= _____

19Z-40. $(874 + 159 + 876)^2(760 + 1300)^2$ -----40= _____

19Z-41. $\left[\frac{2390}{205} \right](50.2 + 52.3)^4$ -----41= _____

19Z-42. $(1/(4.29 \times 10^{-4}))(1410 - 2010)^3$ -----42= _____

19Z-43. $\sqrt{(1140/1930) + 0.478 - 0.275}$ -----43= _____

19Z-44. $\sqrt{1430 - 1290 + 1300} - \sqrt{335}$ -----44= _____

19Z-45. $\sqrt[3]{3.14 - 1750/1310} + 1/\sqrt{0.0571 + 0.15}$ -----45= _____

19Z-46. $\frac{1}{\sqrt{156 + 184 + 187}} + \left(\frac{1}{\sqrt{4.56}} \right)^3$ -----46= _____

19Z-47. A steel pipe, 16 inches in diameter, stretches from Andrews, Texas to Houston, Texas; a distance of 463 miles. If the pipe is filled with natural gas, how much gas is in the pipe? -----47= _____ cu.ft.

19Z-48. Liz found out that a company charges \$250 plus \$8.50 per person to host a birthday party for one of her sons. If there were a total of 21 individuals at the party, how much did it cost? -----48=\$ _____

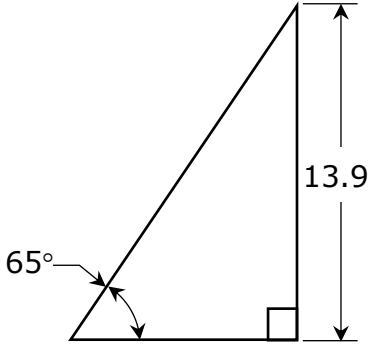
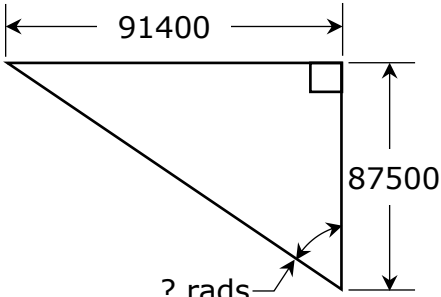
<p>19Z-49.</p> <p style="text-align: center;">RIGHT TRIANGLE</p>  <p style="text-align: center;">Area = ?</p> <p>19Z-49= _____</p>	<p>19Z-50.</p> <p style="text-align: center;">RIGHT TRIANGLE</p>  <p style="text-align: right;">? rads</p> <p>19Z-50= _____ rads</p>
---	--

19Z-51. $\left[\frac{716 + 1060 + \sqrt{2.91 \times 10^6 + 2.32 \times 10^6}}{21/20.2} \right]^3$ -----51= _____

19Z-52. $\frac{(12 + 27.3 - 33.8)^3}{\sqrt{64.2 + 54.1 + 50.4}}$ -----52= _____

19Z-53. $\left[\frac{4820 - 3590 + \sqrt{1.50 \times 10^6 / 4.93}}{-12 + 18.5} \right]^{-4}$ -----53= _____

19Z-54. $(98.6)^2 \sqrt{(3.89)/(334)} - (791 + 182)$ -----54= _____

19Z-55. $\sqrt{\frac{(21900)(1.72 \times 10^5)}{(7220)(48600)}} - 2.69 + 1.06$ -----55= _____

19Z-56. $0.979 + \sqrt{(137)/(87.9)} - (0.358 + 0.182)^2$ -----56= _____

19Z-57. $\sqrt{\frac{(22.5)(656)}{(19.7) + (59.1)}} - 14.7$ -----57= _____

19Z-58. $(\text{deg}) \sin(1800^\circ) + (38.7/20.7)$ -----58= _____

19Z-59. A formula for calculating the final speed of an object dropping in a gravitational field is found by adding the initial speed to the product of the value of the acceleration due to gravity and the time for that acceleration. An object is thrown downward with an initial speed of 5.75 feet/second on the airless Moon where the acceleration due to gravity is 5.36 feet/second². If the object takes 2.75 seconds to land, what is the speed of the object upon landing? -----59= _____ ft/sec

19Z-60. An equation, studied by many high school Physics students, is called the lens equation. It states that the reciprocal of the focal length of a lens is equal to the sum of the reciprocal of the object distance and the reciprocal of the image distance. If the focal length of a lens is 50 millimeters and the image distance is 51 millimeters, what is the object distance?-----60= _____ meters

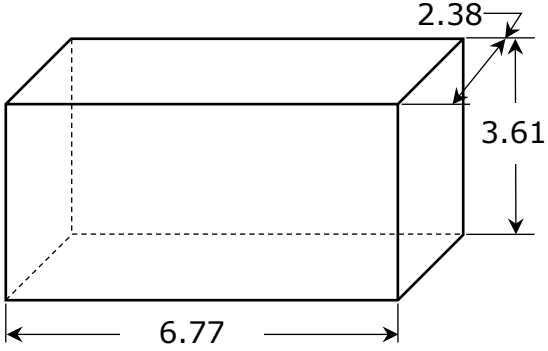
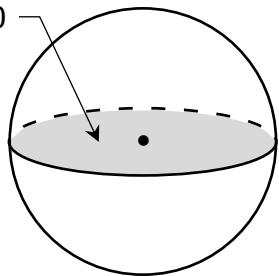
<p>19Z-61. RECTANGULAR BOX</p>  <p style="text-align: center;">Total Surface Area = ?</p> <p>19Z-61= _____</p>	<p>19Z-62. SPHERE</p> <p style="text-align: center;">Shaded Area 967000</p>  <p style="text-align: center;">Volume = ?</p> <p>19Z-62= _____</p>
--	---

19Z-63. $\frac{25!}{22!}$ -----63= _____

19Z-64. $(9.03 \times 10^5 - 5.50 \times 10^5)^{-8} (1.05 \times 10^8)$ -----64= _____

19Z-65. (deg) $\frac{\cos(1.73^\circ)}{3020}$ -----65= _____

19Z-66. (rad) $\frac{\cos(26.8)}{49.3/733}$ -----66= _____

19Z-67. (deg) $\sin(23.6^\circ - 7.43^\circ) + 0.124$ -----67= _____

19Z-68. (rad) $\sin[(52.7 - 47.4)(15.8)]$ -----68= _____

19Z-69. (deg) $\frac{\sin(0.692^\circ) - \tan(0.692^\circ)}{\sin(0.692^\circ)}$ -----69= _____

19Z-70. $(836 + 830 + 589)^{2/5}$ -----70= _____

19Z-71. The international Space Station (ISS) is currently 211 miles above the Earth's surface. If the radius of the Earth is 3960 miles and the ISS take 94.6 minutes to circle once around in orbit, how fast is the ISS moving in orbit around the Earth? -----71= _____ mph

19Z-72. If a light beam travels with the speed of 186,000 miles/second, how long does it take to travel 300 feet across a football field?-----72= _____ s

19Z-73.

SQUARE AND RECTANGLE

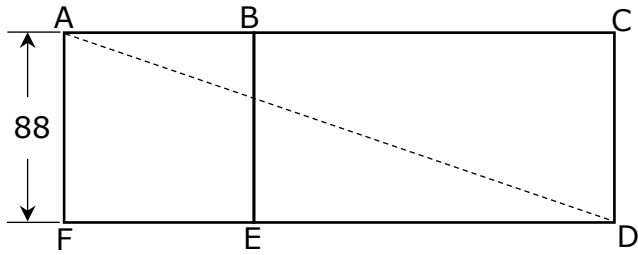

Area BCDE = 2.4 x Square Area

AD = ?

19Z-73= _____

19Z-74.

CUBE AND RIGHT CYLINDER CAVITY

Shaded Area = 4.25×10^9

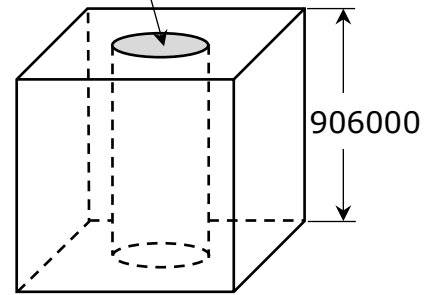

Volume Remaining = ?

19Z-74= _____

19Z-75. $\frac{0.792 + \sqrt{(0.336)(0.796) + (0.453)(1.13)}}{\sqrt{\sqrt{0.278 + 0.252}}}$ -----75= _____

19Z-76. $\frac{(2.26)^{0.407}(8.78)^{0.711}}{(1.19 - 0.46)^{-10}}$ -----76= _____

19Z-77. $\text{Log} \sqrt{\frac{6.36 - 1.36}{(11.4)(7.13)}}$ -----77= _____

19Z-78. $(179)^\pi (7.8)^5 (150 - 140)^5$ -----78= _____

19Z-79. $1 + 2 + 3 + \dots + 595$ -----79= _____

19Z-80. $1 + (0.15) + \frac{(0.15)^2}{2} + \frac{(0.15)^3}{6} + \frac{(0.15)^4}{24}$ -----80= _____

2019 University Interscholastic League MS/JH Calculator Contest C Answer Key

$$\begin{aligned} 19Z-1 &= -467 \\ &= -4.67 \times 10^2 \end{aligned}$$

$$\begin{aligned} 19Z-2 &= -11.0 \\ &= -1.10 \times 10^1 \end{aligned}$$

$$\begin{aligned} 19Z-3 &= -690 \\ &= -6.90 \times 10^2 \end{aligned}$$

$$\begin{aligned} 19Z-4 &= -65.9 \\ &= -6.59 \times 10^1 \end{aligned}$$

$$\begin{aligned} 19Z-5 &= -438 \\ &= -4.38 \times 10^2 \end{aligned}$$

$$\begin{aligned} 19Z-6 &= 299 \\ &= 2.99 \times 10^2 \end{aligned}$$

$$\begin{aligned} 19Z-7 &= 2.04 \\ &= 2.04 \times 10^0 \end{aligned}$$

$$\begin{aligned} 19Z-8 &= -1.81 \\ &= -1.81 \times 10^0 \end{aligned}$$

$$19Z-9 = 3.54 \times 10^6$$

$$19Z-10 = 4.28 \times 10^{10}$$

$$\begin{aligned} 19Z-11 &= 4.43 \\ &= 4.43 \times 10^0 \end{aligned}$$

$$\begin{aligned} 19Z-12 &= 0.881 \\ &= 8.81 \times 10^{-1} \end{aligned}$$

$$\begin{aligned} 19Z-13 &= 521 \\ &= 5.21 \times 10^2 \end{aligned}$$

$$19Z-14 = -4.73 \times 10^7$$

$$\begin{aligned} 19Z-15 &= -27000 \\ &= -2.70 \times 10^4 \end{aligned}$$

$$\begin{aligned} 19Z-16 &= 1.04 \\ &= 1.04 \times 10^0 \end{aligned}$$

$$\begin{aligned} 19Z-17 &= 4.10 \\ &= 4.10 \times 10^0 \end{aligned}$$

$$19Z-18 = 2.58 \times 10^6$$

$$\begin{aligned} 19Z-19 &= -0.907 \\ &= -9.07 \times 10^{-1} \end{aligned}$$

$$\begin{aligned} 19Z-20 &= 0.146 \\ &= 1.46 \times 10^{-1} \end{aligned}$$

$$\begin{aligned} 19Z-21 &= 2080 \\ &= 2.08 \times 10^3 \end{aligned}$$

$$\begin{aligned} 19Z-22 &= 10.4 \\ &= 1.04 \times 10^1 \end{aligned}$$

$$\begin{aligned} 19Z-23 &= -4.82 \\ &= -4.82 \times 10^0 \end{aligned}$$

$$\begin{aligned} 19Z-24 &= 0.752 \\ &= 7.52 \times 10^{-1} \end{aligned}$$

$$19Z-25 = 17.31$$

Dollar Answer

$$19Z-26 = 4840$$

Integer Answer

$$\begin{aligned} 19Z-27 &= -489 \\ &= -4.89 \times 10^2 \end{aligned}$$

$$\begin{aligned} 19Z-28 &= 0.00647 \\ &= 6.47 \times 10^{-3} \end{aligned}$$

$$19Z-29 = -2.04 \times 10^{-13}$$

$$19Z-30 = 6.01 \times 10^{-14}$$

$$\begin{aligned} 19Z-31 &= 0.00705 \\ &= 7.05 \times 10^{-3} \end{aligned}$$

$$\begin{aligned} 19Z-32 &= 0.0328 \\ &= 3.28 \times 10^{-2} \end{aligned}$$

$$\begin{aligned} 19Z-33 &= 0.00238 \\ &= 2.38 \times 10^{-3} \end{aligned}$$

$$\begin{aligned} 19Z-34 &= 0.0347 \\ &= 3.47 \times 10^{-2} \end{aligned}$$

$$\begin{aligned} 19Z-35 &= 0.429 \\ &= 4.29 \times 10^{-1} \end{aligned}$$

$$\begin{aligned} 19Z-36 &= 11.4 \\ &= 1.14 \times 10^1 \end{aligned}$$

$$\begin{aligned} 19Z-37 &= 1.90 \\ &= 1.890 \times 10^0 \end{aligned}$$

$$\begin{aligned} 19Z-38 &= 0.599 \\ &= 5.99 \times 10^{-1} \end{aligned}$$

2019 University Interscholastic League MS/JH Calculator Contest C Answer Key

19Z-39 = 1.16×10^7	19Z-51 = 5.97×10^{10}	19Z-61 = 98.3 = 9.83×10^1	19Z-73 = 312 = 3.12×10^2
19Z-40 = 1.55×10^{13}	19Z-52 = 12.8 = 1.28×10^1	19Z-62 = 7.15×10^8	19Z-74 = 7.40×10^{17}
19Z-41 = 1.29×10^9	19Z-53 = 1.77×10^{-10}	19Z-63 = 13800 = 1.38×10^4	19Z-75 = 2.13 = 2.13×10^0
19Z-42 = -5.03×10^{11}	19Z-54 = 76.2 = 7.62×10^1	19Z-64 = 4.36×10^{-37}	19Z-76 = 0.281 = 2.81×10^{-1}
19Z-43 = 0.891 = 8.91×10^{-1}	19Z-55 = 1.65 = 1.65×10^0	19Z-65 = 0.000331 = 3.31×10^{-4}	19Z-77 = -0.606 = -6.06×10^{-1}
19Z-44 = 19.6 = 1.96×10^1	19Z-56 = 1.94 = 1.94×10^0	19Z-66 = -1.43 = -1.43×10^0	19Z-78 = 3.45×10^{16}
19Z-45 = 3.41 = 3.41×10^0	19Z-57 = -1.01 = -1.01×10^0	19Z-67 = 0.402 = 4.02×10^{-1}	19Z-79 = 177000 = 1.77×10^5
19Z-46 = 0.146 = 1.46×10^{-1}	19Z-58 = 1.87 = 1.87×10^0	19Z-68 = 0.883 = 8.83×10^{-1}	19Z-80 = 1.16 = 1.16×10^0
19Z-47 = 3.41×10^6	19Z-59 = 20.5 = 2.05×10^1	19Z-69 = -7.29×10^{-5}	
19Z-48 = 428.50 Dollar Answer	19Z-60 = 2.55 = 2.55×10^0	19Z-70 = 21.9 = 2.19×10^1	
19Z-49 = 45.0 = 4.50×10^1		19Z-71 = 16600 = 1.69×10^4	
19Z-50 = 0.807 = 8.07×10^{-1}		19Z-72 = 3.05×10^{-7}	